

MOD:XEBC-06EU-E1LM



ENGLISH

TECHNICAL DATA

- 01 POWER
- 03 FREQUENCY
- 04 POWER SUPPLY CABLE TYPE
- 05 EXTERNAL Ø OF POWER SUPPLY CABLE
- 06 VOLTAGE / POWER CABLE SECTION / CURRENT

10,1 kW
50 / 60 Hz
H07RN-F
13 mm

380-415 V~3PH+N+PE
5G x 2,5 mm²
Circuit Breaker 20 A
I1=15 A - I2=15 A - I3=13,5 A - In=1,5 A

220-240 V~3PH+PE
4G x 4 mm²
Circuit Breaker 32 A
I1=26 A - I2=24,5 A - I3=24,5 A - In=

- 10 WATER PRESSURE
- 11 MAX FOOD LOAD
- 13 WATER MAX CONSUMPTION
- 02 NOMINAL HEAT INPUT
- 18 CAVITY DIMENSIONS (W - D - H)
- 20 IP PROTECTION CLASS

150-600 kPa / 21-87 psi kPa
30 kg
7 l/h @ 200 kPa
9,4 kW
716x561x560 mm
X4

ITALIANO

- 01 POTENZA
- 03 FREQUENZA
- 04 TIPO DI CAVO ALIMENTAZIONE
- 05 Ø ESTERNO CAVO DI ALIMENTAZIONE
- 06 TENSIONE / SEZIONE CAVI ALIMENTAZIONE / CORRENTE
- 10 PRESSIONE ACQUA
- 11 CARICA MAX CIBO
- 13 CONSUMO MAX ACQUA
- 02 POTENZA TERMICA NOMINALE
- 18 DIMENSIONI CAMERA COTTURA (L - P - H)
- 20 GRADO PROTEZIONE IP

FRANCAIS

- 01 PUISSANCE ELECTRIQUE
- 03 FREQUENCE
- 04 TYPE DE CABLE D'ALIMENTATION
- 05 Ø EXTERNE DU CABLE D'ALIMENTATION
- 06 TENSION / SECTION CABLE D'ALIM.
- 10 PRESSION DE L'EAU
- 11 CHARGE MAXIMALE D'ALIMENT
- 13 CONSOMMATION MAX DE L'EAU
- 02 DEBIT THERMIQUE NOMINAL
- 18 DIMENSIONS CHAMBRE DE CUISSON (L - P - A)
- 20 INDICE DE PROTECTION IP

ESPAÑOL

- 01 POTENCIA
- 03 FRECUENCIA
- 04 TIPO DE CABLE DE ALIMENTACION
- 05 Ø CABLE EXTERNO DE ALIMENTACION
- 06 TENSION / SECCION CABLES DE ALIMENTACION
- 10 PRESION AGUA
- 11 CARGA MAX. DE ALIMENTOS
- 13 CONSUMO MAX DE AGUA
- 02 POTENCIA TERMICA NOMINAL
- 18 DIMENSIONES CÁMARA DE COCCIÓN (An - Pr - Al)
- 20 GRADO DE PROTECCION IP

DEUTSCH

- 01 ELEKTRISCHE LEISTUNG
- 03 FREQUENZ
- 04 ZULEITUNGSKABELTYP
- 05 AUSSENDURCHMESSER DES VERSORGUNGSKABELS
- 06 KABELQUERSCHNITT UND VERSORGUNGSSPANNUNG
- 10 WASSERDRUCK
- 11 MAX. SPEISENFASSUNGSVERMOGEN
- 13 MAXIMUM WASSERVERBRAUCH
- 02 NOMINALE WARMELEISTUNG
- 18 GRÖÖE DES KOCHKAMMERS (B - T - H)
- 20 SCHTZART IP



MOD:XEBC-06EU-E1LM



ENGLISH - DRAWINGS

2	TERMINAL BOARD POWER SUPPLY
3	UNIPOTENTIAL TERMINAL
6	TECHNICAL DATA PLATE
7	SAFETY THERMOSTAT
8	3/4" THREAD WATER INLET
10	Rotor.KLEAN CONNECTION
11	CAVITY DRAIN PIPE
12	HOT FUMES EXHAUST CHIMNEY
13	ACCESSORIES CONNECTION
27	COOLING AIR OUTLET

ITALIANO - DISEGNI

2	MORSETTIERA ALIMENTAZIONE
3	MORSETTO EQUIPOTENZIALE
6	TARGHETTA DATI TECNICI
7	TERMOSTATO DI SICUREZZA
8	INGRESSO ACQUA 3/4"
10	INGRESSO Rotor.KLEAN
11	SCARICO CAMERA DI COTTURA
12	USCITA FUMI CALDI
13	COLLEGAMENTO ACCESSORI
27	USCITA ARIA DI RAFFREDDAMENTO

FRANCAIS - ENCOMBREMEN

2	BOITE A BORNES D'ALIMENTATION
3	SUPPORT BORNE EQUIPOTENTIELLE
6	PLAQUETTE SIGNALÉTIQUE
7	THERMOSTAT DE SÉCURITÉ
8	ARRIVÉ D'EAU FIÉLT 3/4"
10	ENTRÉE Rotor.KLEAN
11	SORTIE DE L'EAU RACCORD
12	SORTIE DES FUMÉES CHAUDES
13	JONCTION DES ACCESSOIRES
27	SORTIE D'EAU DE REFROIDISSEMENT

ESPAÑOL - DISEÑOS

2	CAJA DE CONEXION
3	SEDE BORNE EQUIPOTENCIAL
6	TARJETA DE CARACTERISTICAS TECNICAS
7	TERMOSTATO DE SEGURIDAD
8	ENTRADA DE AGUA 3/4"
10	INGRESO Rotor.KLEAN
11	DESCARGA CAMARA DE COCCION
12	SALIDA HUMOS CALIENTES
13	CONEXION ACCESORIOS
27	SALIDA DEL AIRE DE ENFRIAMIENTO

DEUTSCH - ZEICHNUNGEN

2	ZULEITUNGSKLEMMLEISTE
3	GLEICHPOTENTIELLE KLAMMER
6	TYPENSCHILD
7	SICHERHEITSTHERMOSTAT
8	WASSEREINZUG 3/4" GEWINDE
10	Rotor.KLEAN EINGANG
11	WASSERAUSLASS GEWINDE
12	ABZUGSHAUBE
13	ZUBEHÖRTEILENVERBINDUNG
27	KÜHLLUFTAUSRITZ

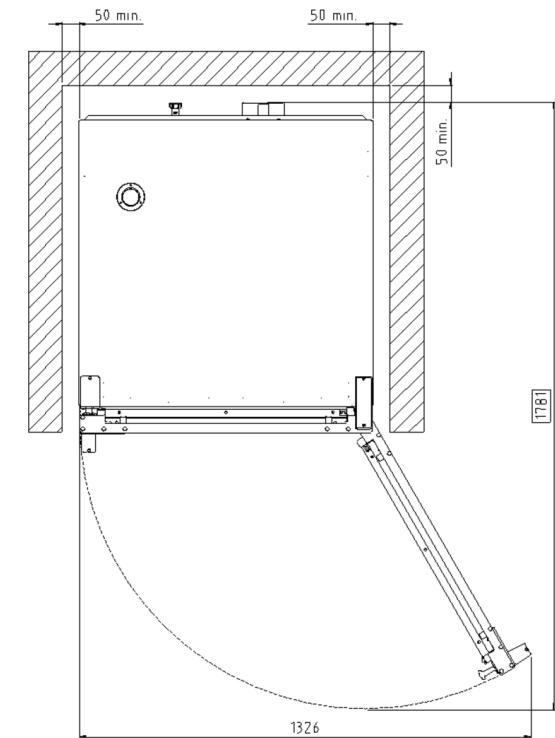
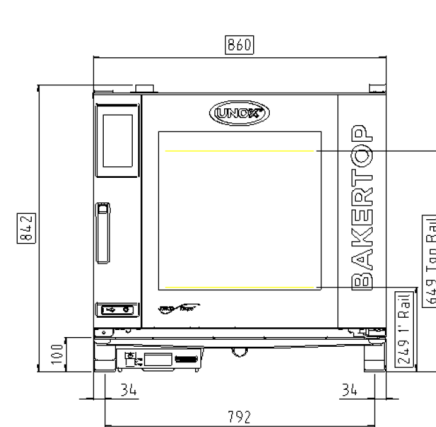
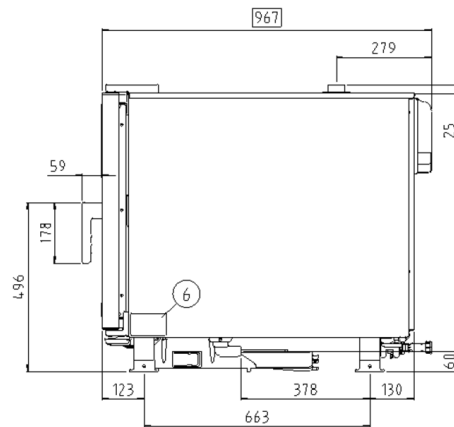
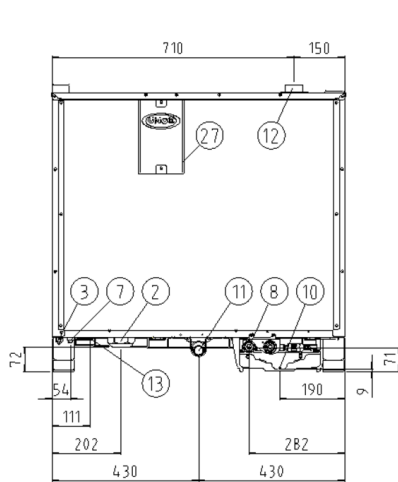

MOD:XEBC-06EU-E1LM

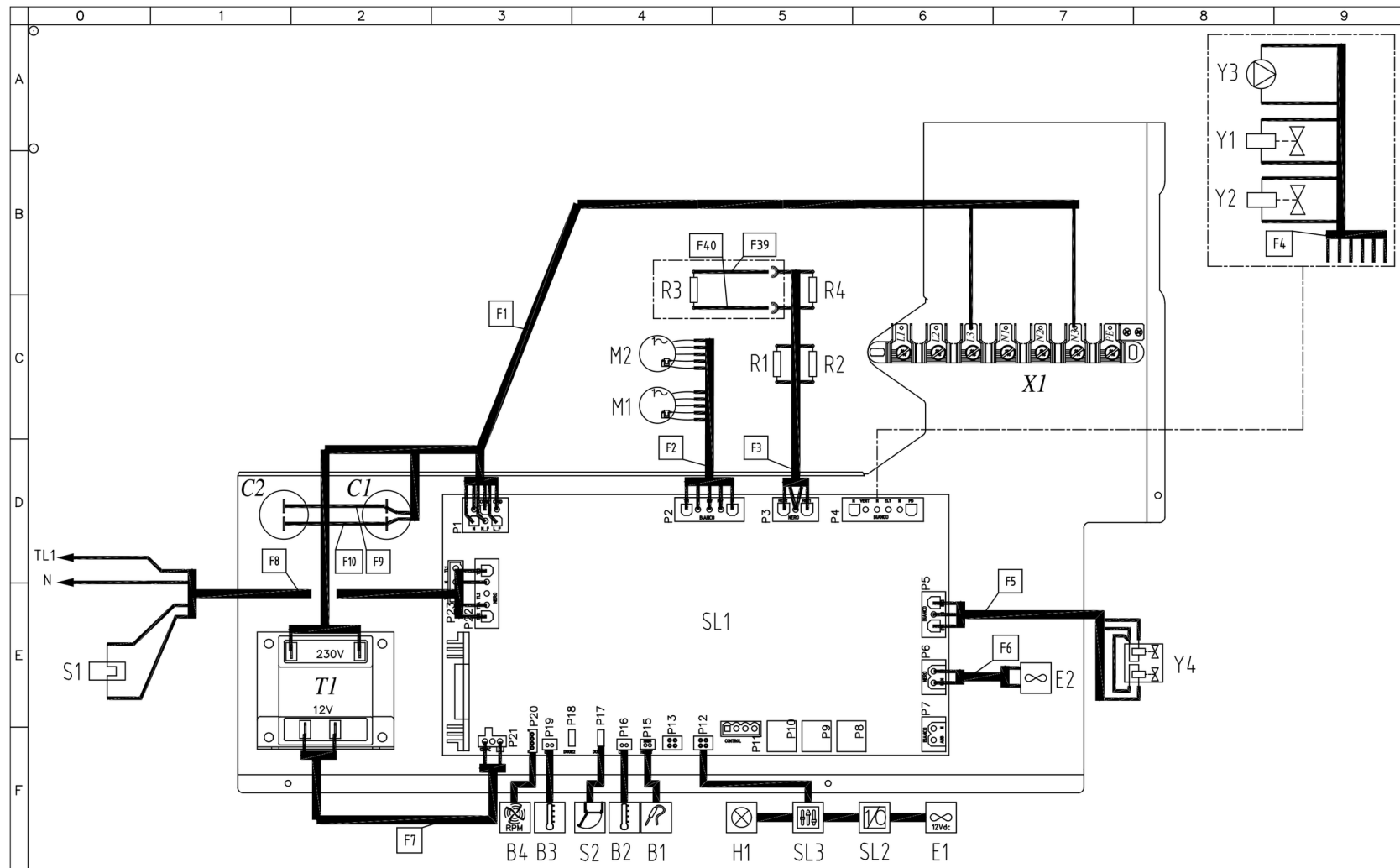

MOD:XEBC-06EU-E1LM

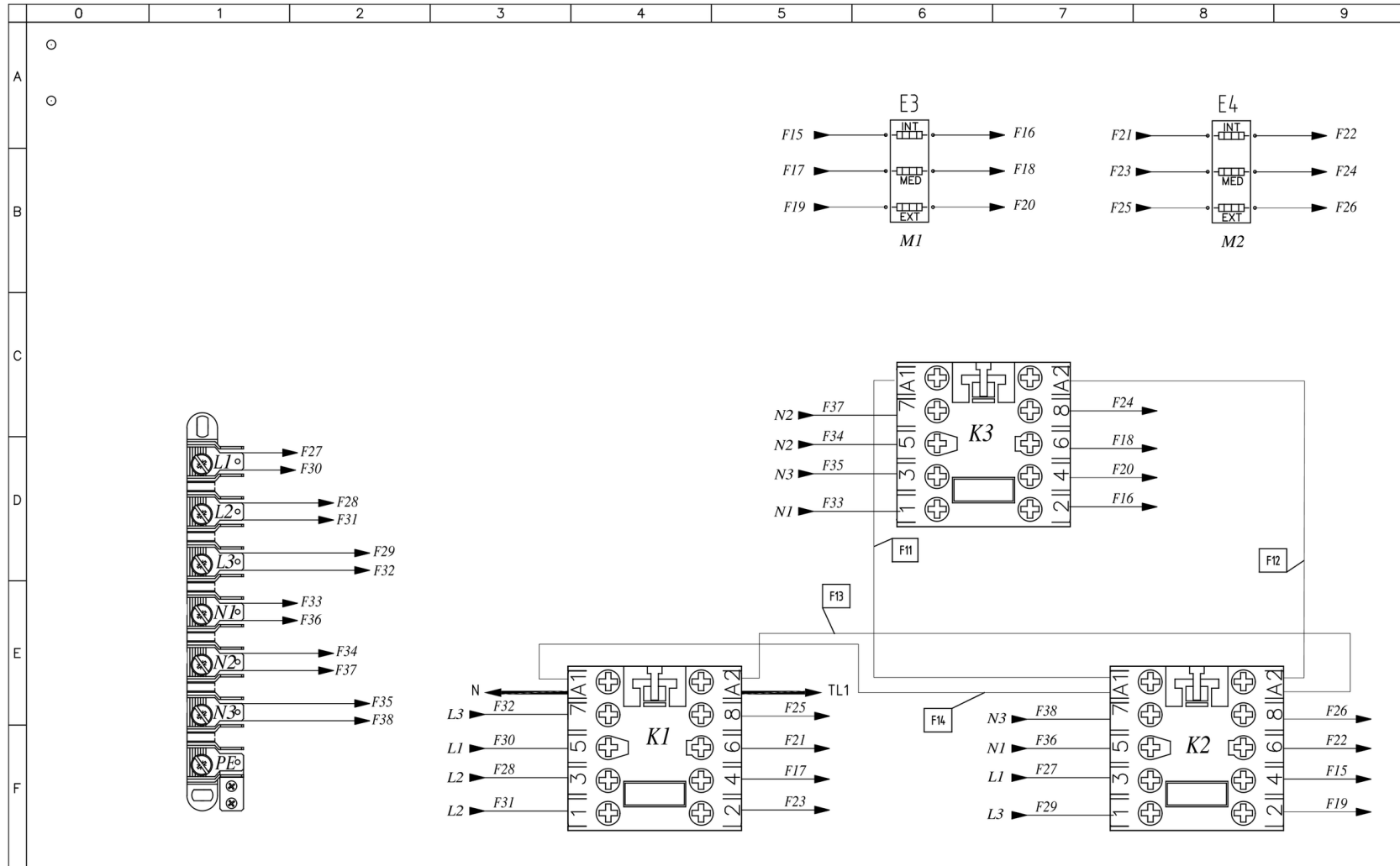

MOD:XEBC-06EU-E1LM



ED1408A
POWER SUPPLY - CONNECTION DIAGRAM

380-415V ~ 3PH + N + PE 50/60HZ

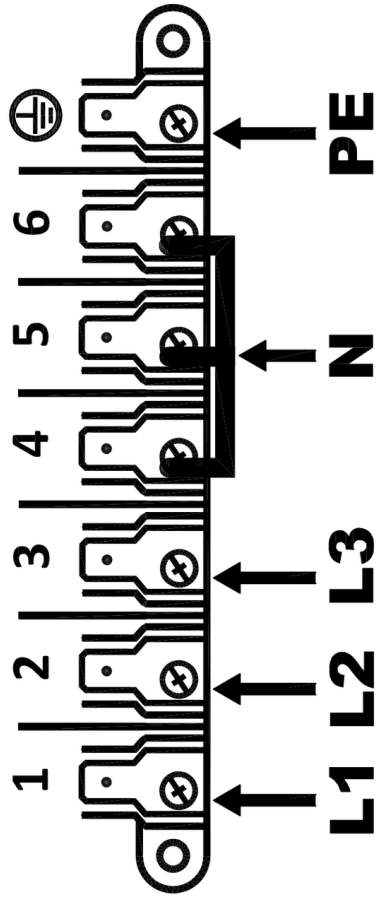

220-240V ~ 3PH + PE 50/60HZ

